

Beat Discovery

Turn the knobs and experience the grooves. Press Bank and hold BANK and turn LENGTH.

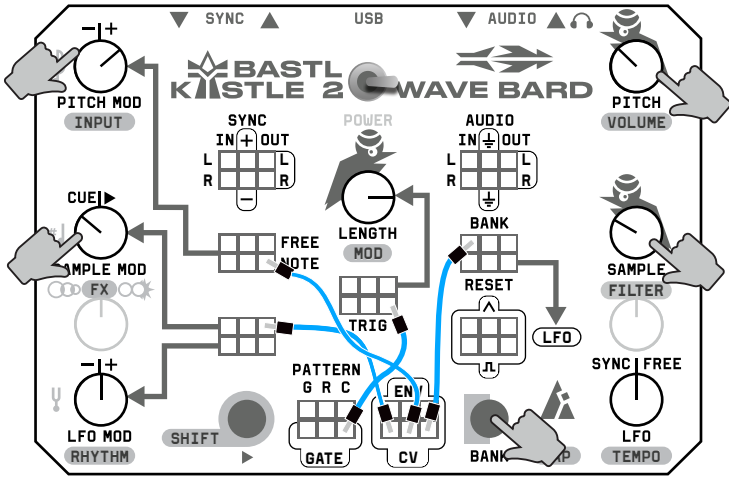

On & Off the Grid

Sample mod to the left in CUE will keep you on the grid, to the right it will GROOVE.

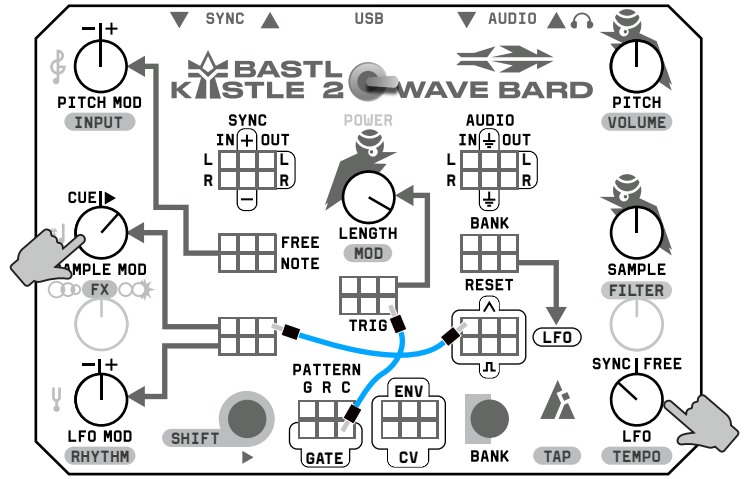

Free Jazz

Push SAMPLE MOD from left to the right to fire drum rolls. Adjust LFO to jam.

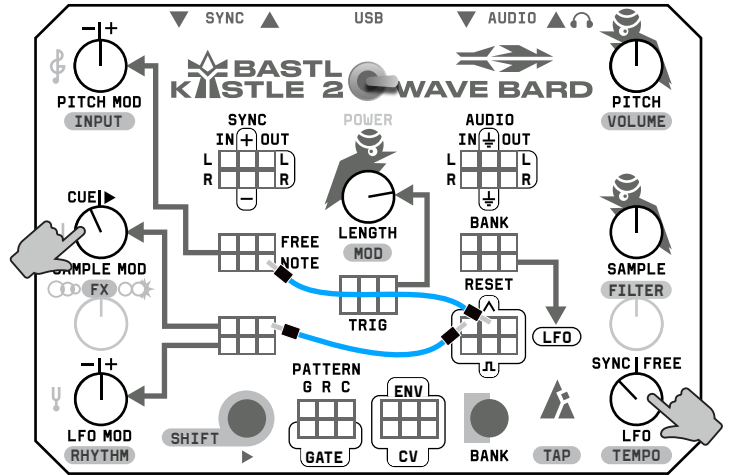

Tempo shuffle

Control tempo by CV modulated LFO for rhythm irregularity. Adjust TEMPO divider.

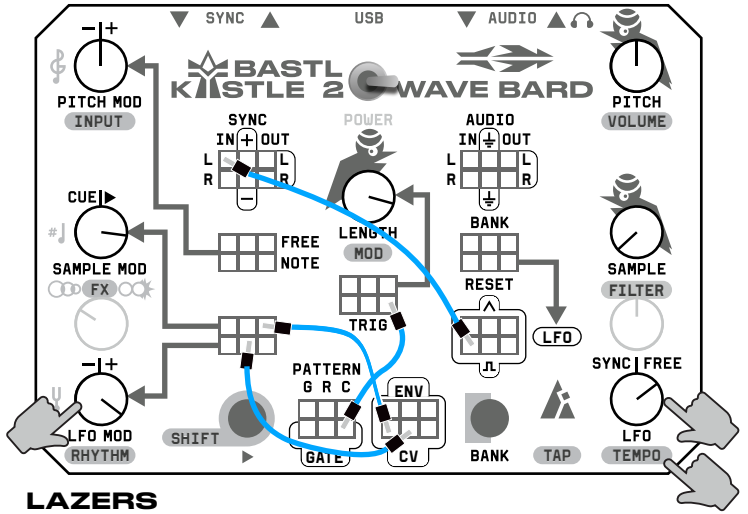

Ratchets

Modulate rate of synced LFO that triggers the samples to get ratchets on the grid.

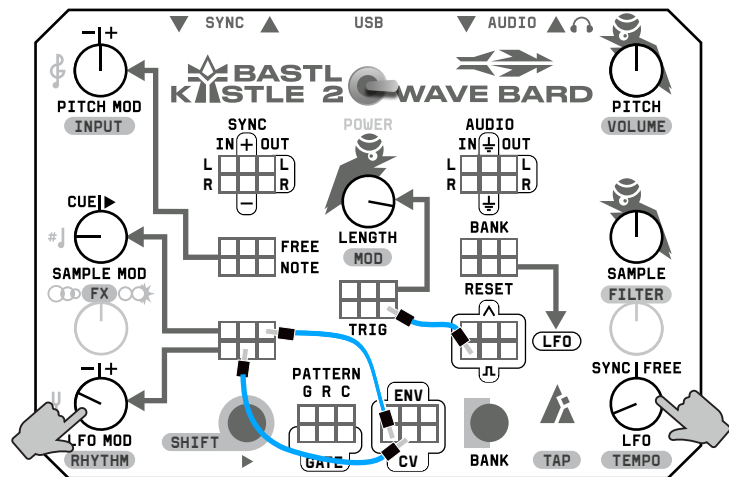

LAZERS

PiuPiu. Modulate the pitch with the ENvelope.

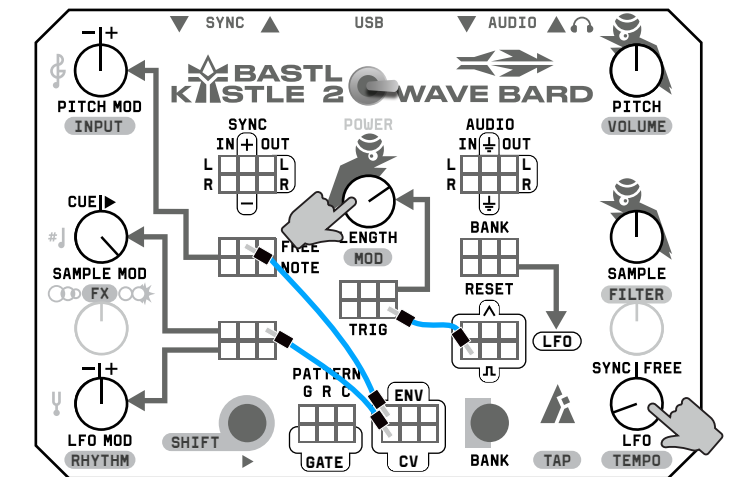

Crazy fast delay

Delay is tempo synced, so sync it to fast LFO, made faster by patching + to the LFO MOD.

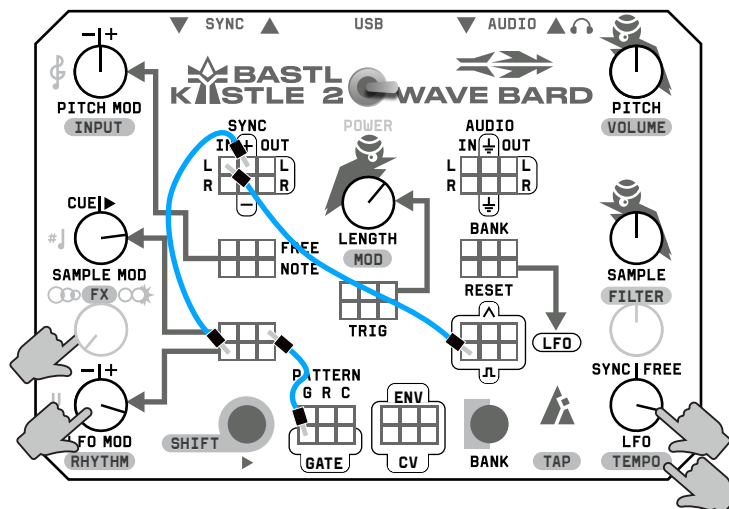

Retrig heaven

LFO triggers, combined with GATE. LFO speeds up when ENvelope is up and makes retrigs.

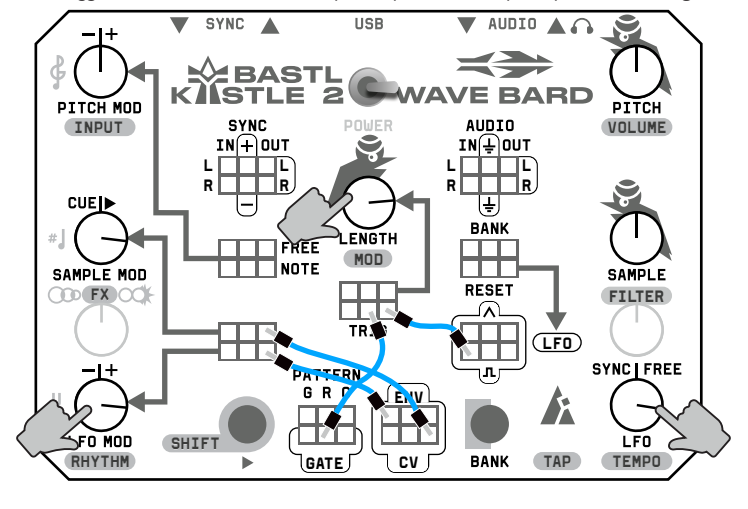

Walking Backwards

Modulate the LENGTH from reverse to forward direction. Adjust Length to get different accents.

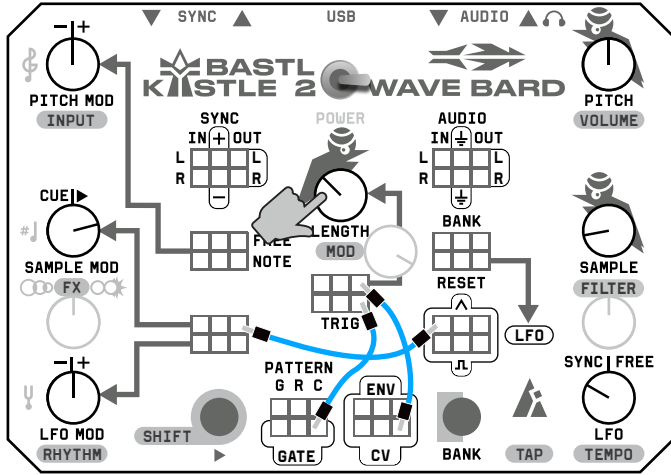

Hyper Polka

The simplest of beats and yet very efficient. Especially when you modulate the BANK a bit.

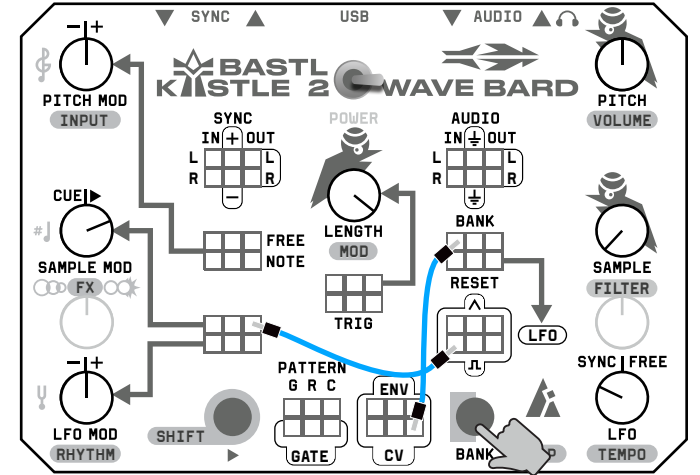

Anybody said ambient textures?

Turn down the TEMPO and LFO, turn up the DELAY and explore some reversed textures

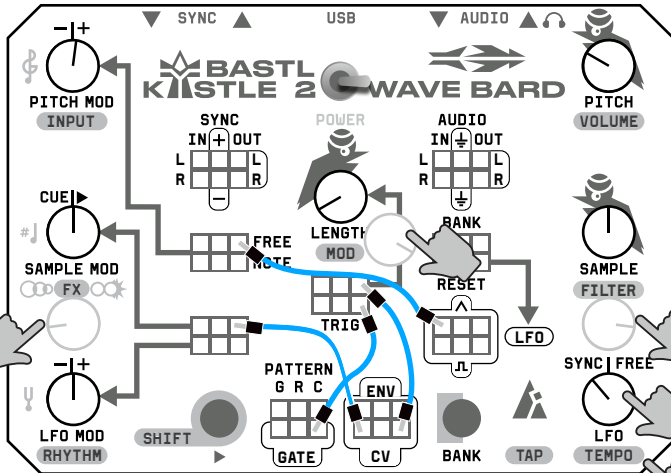

Linear drumming with tuplets

LFO in the SAW configuration. SAMPLE MOD sets how many sounds get triggered.

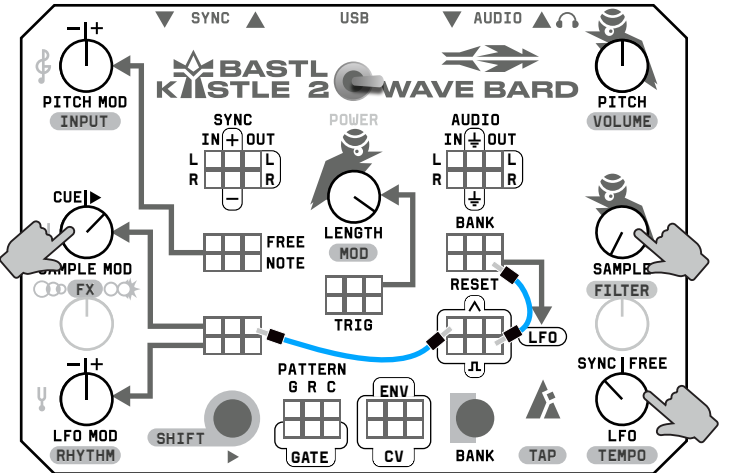

TOTALLY RADOM

C PATTERN input to "+" is RANDOM CV. Use it to create random rhythms.

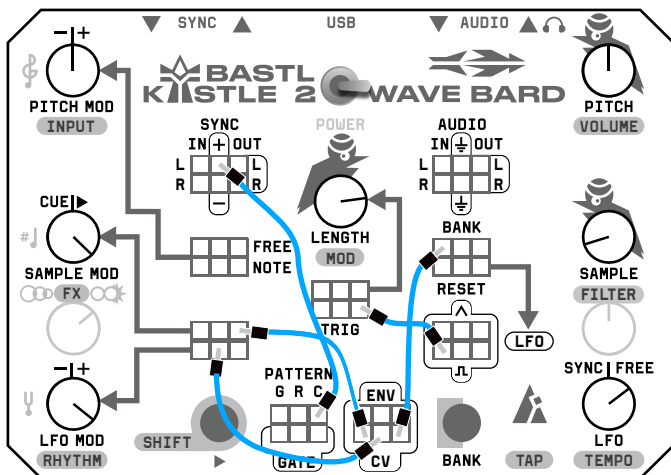

Drunk groove

Fast-ish LFO being reset by a GATE RHYTHM triggers the samples off grid between GATES.

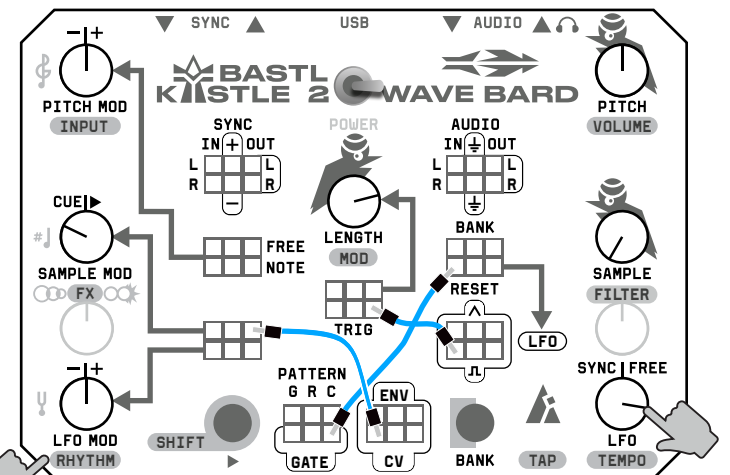

Odd beat rhythms

Pick RHYTHM with only first beat to reset free LFO. The LFO shortens the PATTERN oddly.

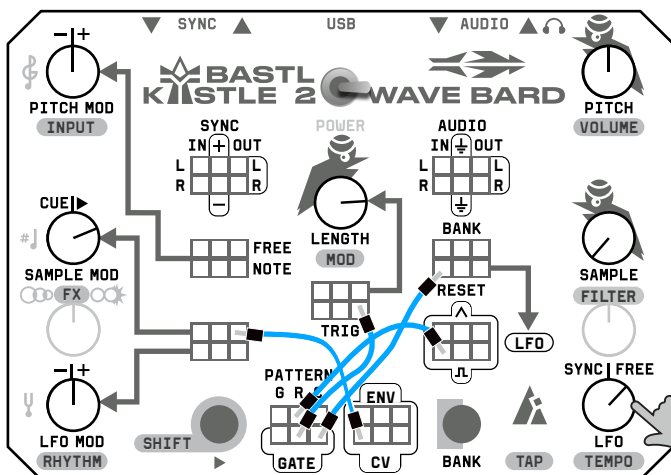

??WHAT IS HAPPENING???

NOTHING IS STABLE no idioms YOU ARE SENTENCED TO EXPERIEMNTS FOR LIFE!

