

Ducking Delay

Great for vocals or when delay should go out of the way, The ENV takes away the effect.

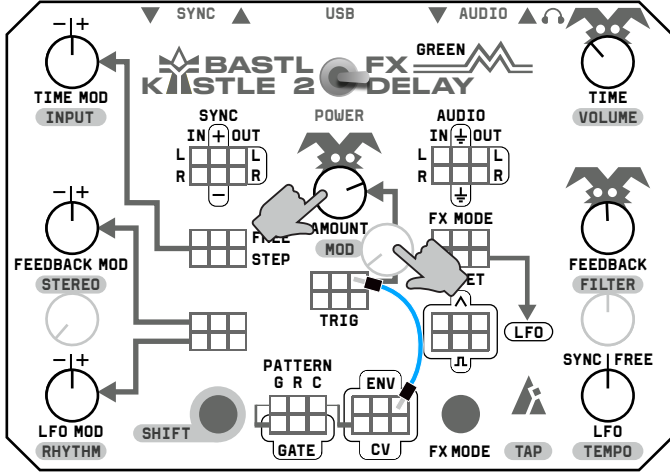

Vibrato + Chorus and Flanger

Adds pitch modulation. Lower AMOUNT for chorus effect, add FEEDBACK for flanger.

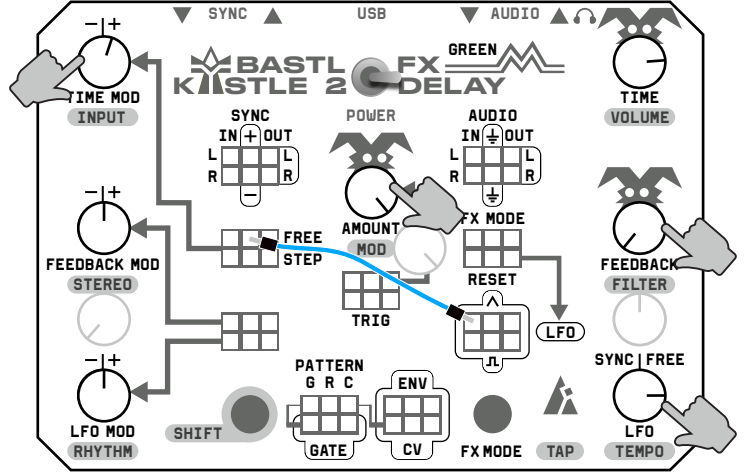

Broken Tape

Randomly modulated triangle LFO modulating the delay time will amplify the nostalgia.

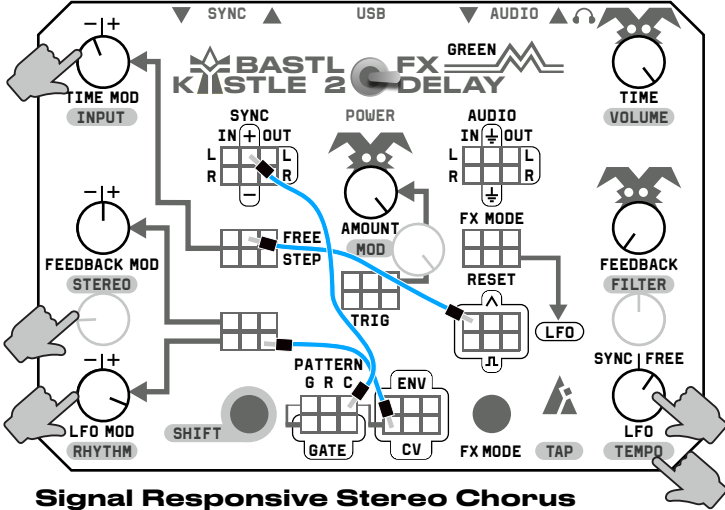

Haas Effect

Detune delay between left and right channel to widen the stereo field. #sounddesign

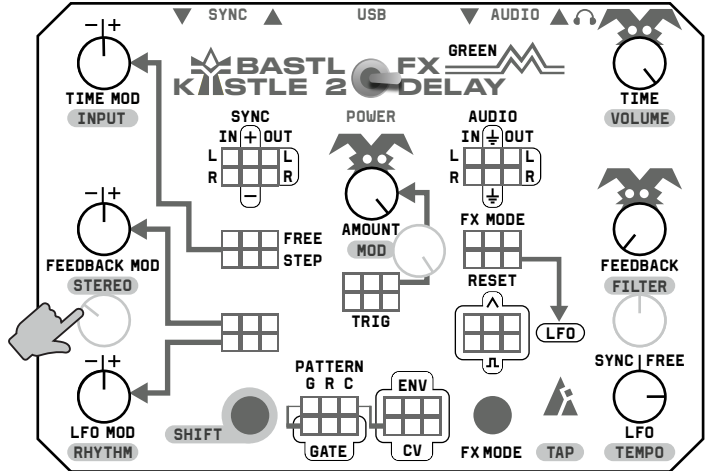

Signal Responsive Stereo Chorus

The ENV resets the modulation with transients. Add FEEDBACK for flanging.

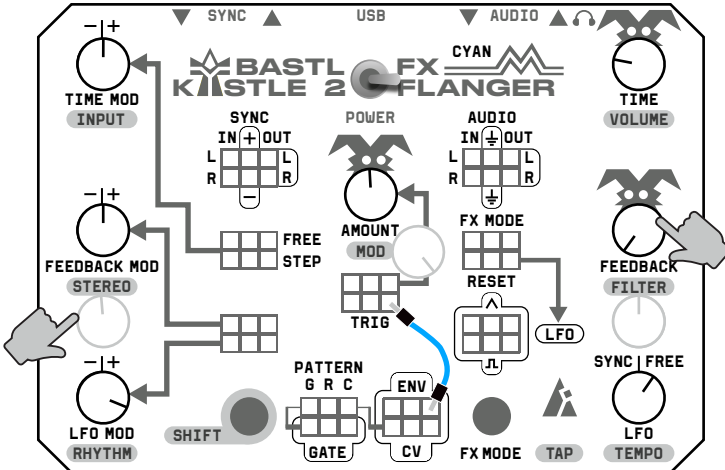

Auto Freezer

Use either ENV to trigger refreeze. Adjust INPUT to set sensitivity when using ENV.

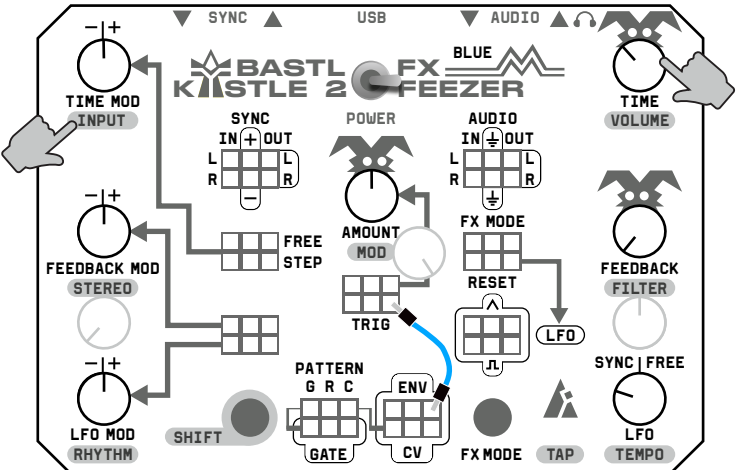

Rhythm Freezer

Refreeze with CV modulated synced LFO. Add variation with modulation of TIME.

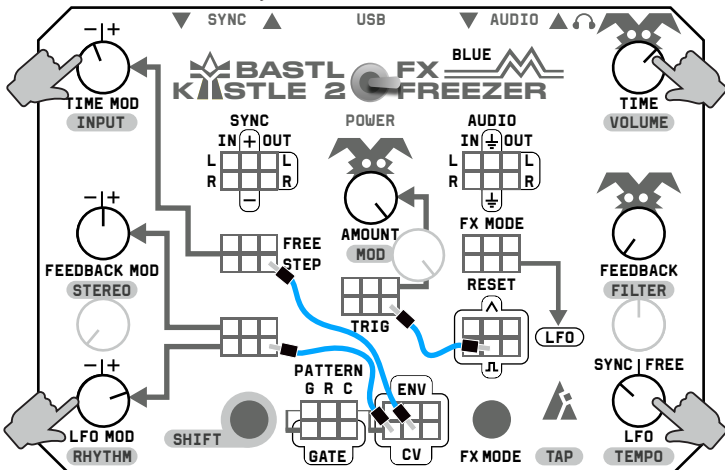

Rhythm Glitcher

Create rhythmical freezes synchronised with tempo. Be nuanced or totally glitch out!

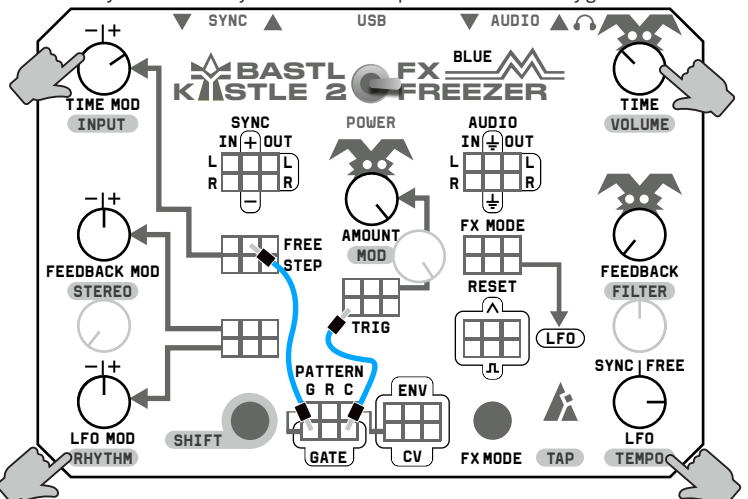

Tail Panner & Distorter

Loud parts stay centered and tails get panned consistently. Add FEEDBACK to distort them.

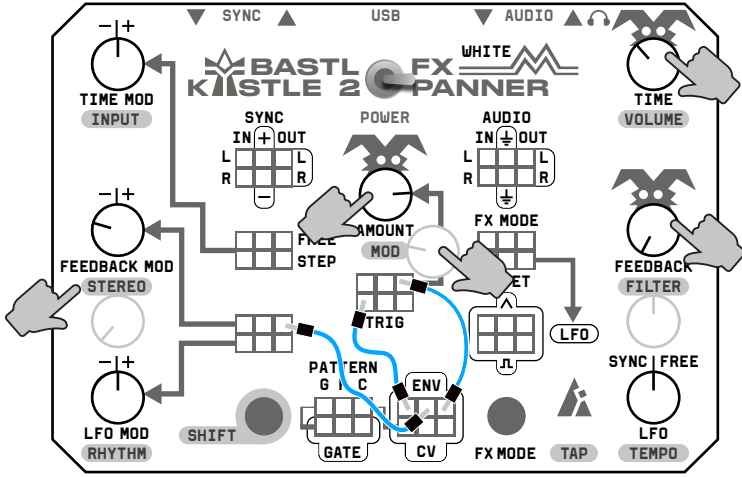

Stereo Ring Mod

Speed up panner to audio rate to create stereo ring modulation. Modulate time for more fun.

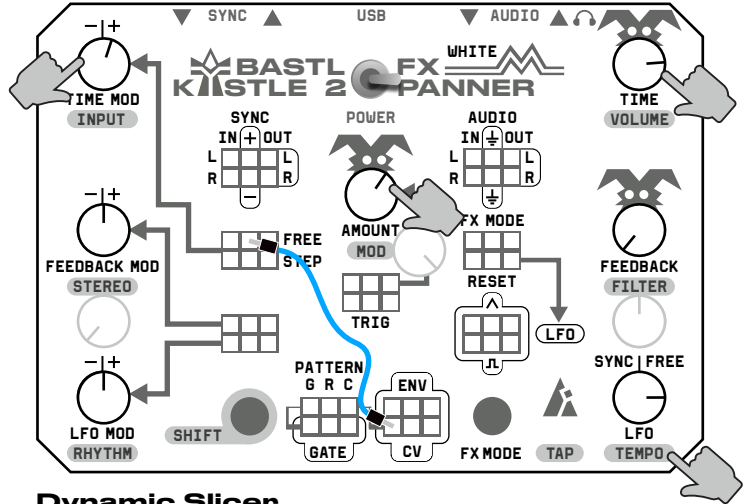

LO-FI Phaser

Animate downsampling frequency with LFO to create subtle modulation. Add some STEREO.

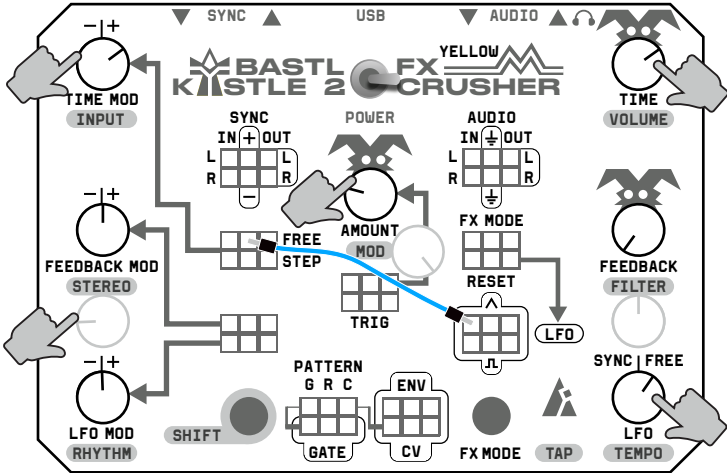

Dynamic Slicer

Modulate the slicer decay with slow LFO to create very dynamic chops.

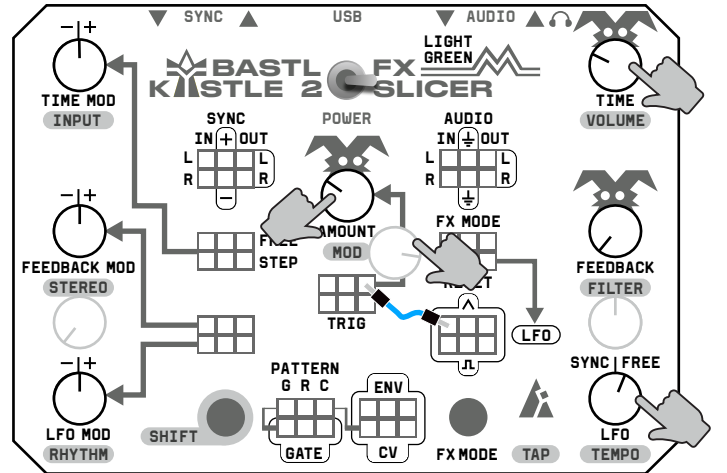

Pitched Repeater (with crickets)

You can patch ENV to TRIG to align with the input. Add FEEDBACK for crickets.

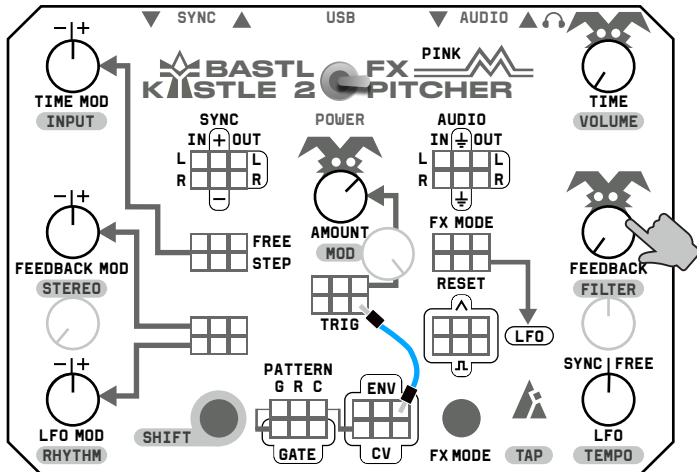

Twin Peaks Reverse Speech

Hello agent Cooper. I'll see again you in 25 years. Meanwhile.

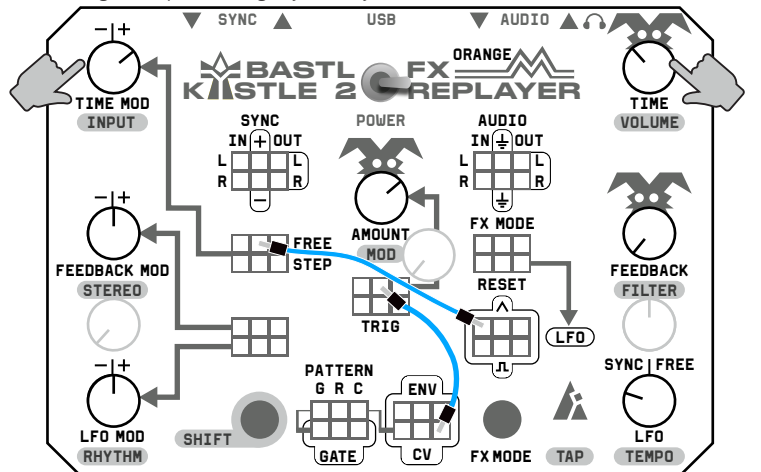

Space Vinyl Saucer

Adjust TEMPO for modulation speed and add FEEDBACK for intergalactic lift off.

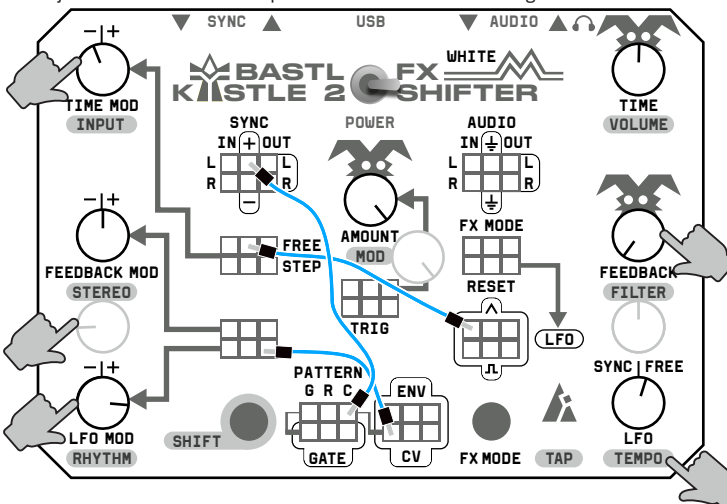

8bit Synth

LFO is VCO now, use AMOUNT and FILTER for timbral modulation. GATE can add accents.

